

OPERATING PERFORMANCE

Operating Weight - Cab	3,760 kg
Operating Weight - Canopy	3,605 kg
Bucket Capacity (Heaped)	0.105 m ³
Slew Speed	9.0 min ⁻¹
Travel Speed	
1st	3.0 km/h
2nd	4.1 km/h
Gradeability	25°
Ground Pressure - Cab	32.1 kPa
Ground Pressure - Canopy	30.8 kPa
Maximum Bucket Breakout Force	27.1 kN
Maximum Arm Digging Force (1,260 mm Arm)	20.6 kN
Maximum Arm Digging Force (1,410 mm Arm)	19.1 kN
Traction Force	40.5 kN
Boom Swing Angle (Left/Right)	70° / 55°

ENGINE

Model	Kubota / V1505
Rated Output (ISO 14396)	18.2 kW / 2,300 min ⁻¹
Maximum Torque	95.8 Nm / 1,700 min ⁻¹
Displacement	1,498 ml
Alternator	12V - 0.72 kW
Battery (IEC 60095-1)	12V - 64 A·h

FLUID CAPACITY

Engine Lubrication	6.7 L
Cooling System	12.5 L
Fuel Tank Capacity	43.5 L
Hydraulic Reservoir Capacity	28.4 L
Hydraulic System Capacity	59.0 L

HYDRAULIC SYSTEM

P1, P2	Variable Displacement Pump
Flow Rate	42.6 L/min
Relief Pressure	24.5 MPa
P3	Gear Pump
Flow Rate	21.9 L/min
Relief Pressure	20.6 MPa
Service Port 1	
Flow Rate	64.4 L/min
Hydraulic Pressure	21.0 MPa
Service Port 2	
Flow Rate	21.9 L/min
Hydraulic Pressure	20.6 MPa
Service Port 3	
Hydraulic Pressure	20.6 MPa
Service Port 4	
Flow Rate	21.9 L/min
Hydraulic Pressure	20.6 MPa

SAFETY and HEALTH

Vibration Levels	
Hand / Arm	≤ 2.5 m/s ²
Body	≤ 0.5 m/s ²
Noise Level	
Sound Power Level	L _{WA} 93 dB



Up to 4 Service Ports (Optional)



Great Stability



All Steel Construction



TFM (Optional)

TB335R Compact Excavator

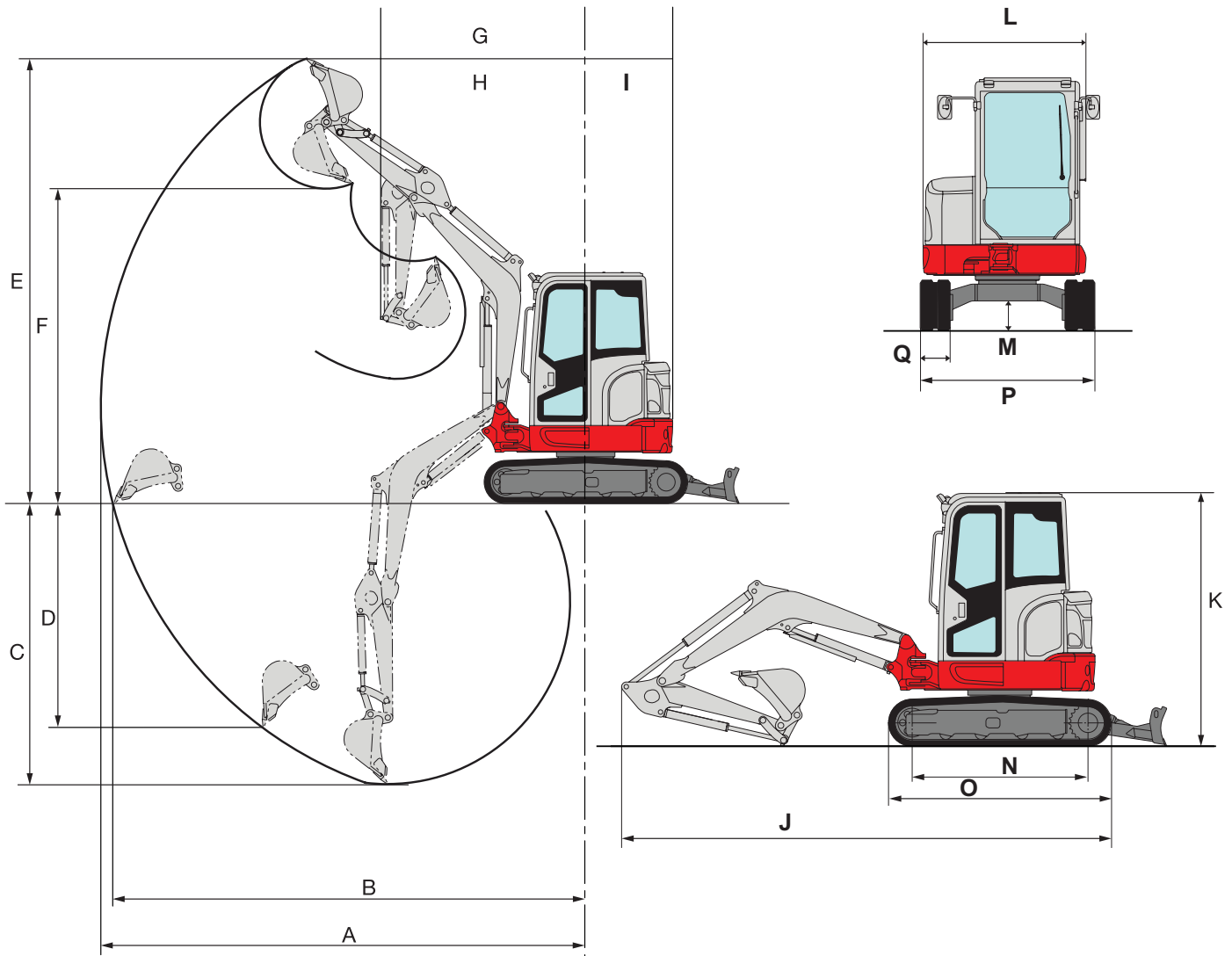

MACHINE DIMENSIONS	1,260 mm Arm	1,410 mm Arm
A Maximum Reach	5,285 mm	5,430 mm
B Maximum Reach at Ground Level	5,115mm	5,305 mm
C Maximum Digging Depth	3,055 mm	3,205 mm
D Maximum Vertical Digging Depth	2,365 mm	2,505 mm
E Maximum Height of Cutting Edge	4,845 mm	4,945 mm
F Maximum Dumping Height	3,430 mm	3,530 mm
G Front Swing Radius	2,240 mm	2,265 mm
H Front Swing Radius with Boom Offset	1,835 mm	1,860 mm
I Slew Radius	950 mm	
J Overall Length	4,870 mm	4,890 mm
K Overall Height (Cab / Canopy)	2,490 mm / 2,520 mm	
L Upper Structure Overall Width (Cab / Canopy)	1,625 mm / 1,620 mm	
M Ground Clearance	295 mm	
N Crawler Base	1,750 mm	
O Crawler Overall Length	2,215 mm	
P Crawler Overall Width	1,740 mm	
Q Crawler Shoe Width	300 mm	