

CB 24

V1/2/3/4/5/6



DESCRIZIONE



Sabbiatrice a getto libero con corredo di lavoro, cassa sabbia, tubo abrasivo raccordato, ugello, setaccio, maschera floscia o casco aerato.

DATI TECNICI

Pressione massima d'esercizio	7 bar
Capacità abrasivo	24 lt
Altezza	80 cm
Diametro	50 cm
Peso a vuoto	32 kg

DESCRIPTION



Free jet sandblasting machine with work kit, sand tank, jointed abrasive hose, nozzle, sifter, non-rigid mask or aerated helmet.

TECHNICAL DATA

Maximum operating pressure	7 bar
Abrasive capacity	24 lt
Height	80 cm
Diameter	50 cm
Loadless weight	32 kg

SABBIATRICI

SANDBLASTING MACHINES

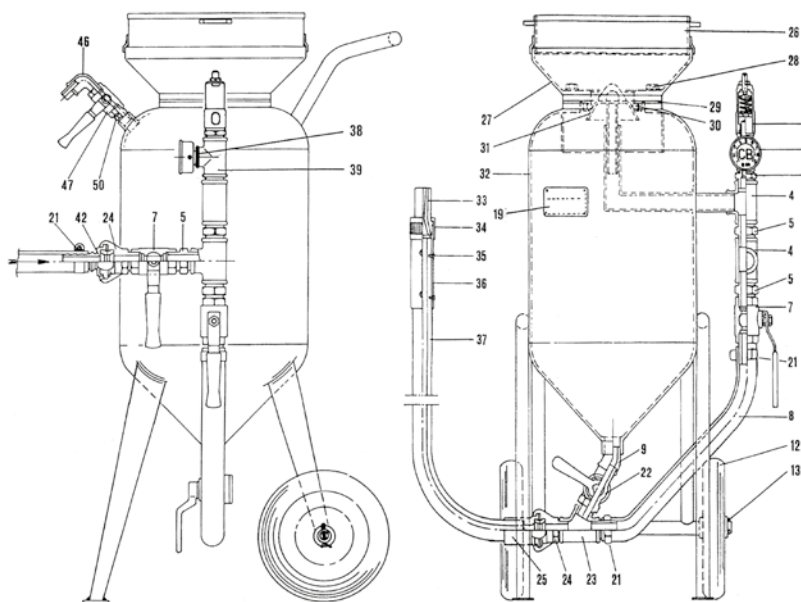

1	V0006	Safety valve
2	V0202	Manometer for pressure control of abrasive container
3	V0203	Reduced nipple 3/4 - 3/8
4	V0007	T-joint
5	V0008	Nipple
7	V0009	Air batcher valve
8	V0012	Conjunction extension
9	V0015	45° curve
12	V0013	Wheel
13	V0014	Cotter pin
19	V0403	Plate
21	V0011	Nipple 3/4 A.P.
22	V0016	Abrasive batcher valve
23	V0017	45° t-joint
24	RA3	Fast hooking connection
25	RA13	Sand tube connection

26	V0225	Sieve
27	V0023	Funnel cover
28	V0227	Cover fixing screw
29	V0004	Gasket for cover
30	V0005	Gasket for closure head
31	V0022	Closure head
32	V0021	Abrasive container
33	UG1	Nozzle (see nozzle table)
34	V0232	Nozzle fixing bush
35	V0233	Handle fixing screw
36	RA10	Nozzle holder
37	TU1	Tube for abrasive
38	V0236	Reduction 3/8 - 1/4
39	V0238	T-connection 3/8
46	V0024	Crank 3/8
47	V0025	Air exhaust valve 3/8
50	V0026	Nipple 3/8



CB24-V1 Sabbiatrice con corredo di lavoro, cassa sabbia, tubo abrasivo d.16x30 da mt.5 raccordato, ugello, setaccio, cappuccio floscio M01.

CB24-V2 Sabbiatrice con corredo di lavoro, cassa sabbia, tubo abrasivo d.16x30 da mt.10 raccordato, ugello, setaccio, cappuccio floscio M01.

CB24-V3 Sabbiatrice con corredo di lavoro, cassa sabbia, tubo abrasivo d.16x30 da mt.5 raccordato, ugello, setaccio, tubo atossico d.8x17 da mt.5 raccordato, kit aerazione, casco aerato M05.

CB24-V4 Sabbiatrice con corredo di lavoro, cassa sabbia, tubo abrasivo d.16x30 da mt.10 raccordato, ugello, setaccio, tubo atossico d.8x17 da mt.10 raccordato, kit aerazione, casco aerato M05.

CB24-V5 Sabbiatrice con corredo di lavoro, cassa sabbia, tubo abrasivo d.16x30 da mt.5 raccordato, ugello, setaccio, tubo atossico d.8x17 da mt.5 raccordato, kit aerazione, casco aerato M06.

CB24-V6 Sabbiatrice con corredo di lavoro, cassa sabbia, tubo abrasivo d.16x30 da mt.10 raccordato, ugello, setaccio, tubo atossico d.8x17 da mt.10 raccordato, kit aerazione, casco aerato M06.



CB24-V1 Sand-blasting machine with work set, sand case. Abrasive tube d.16x30 mt.5 coupled, nozzle, sieve. Soft cap M01.

CB24-V2 Sand-blasting machine with work set, sand case. Abrasive tube d.16x30 mt.10 coupled, nozzle, sieve. Soft cap M01.

CB24-V3 Sand-blasting machine with work set, sand case. Abrasive tube d.16x30 mt.5 coupled, nozzle, sieve. Atoxic tube d. 8x17 mt.5 coupled, air kit. Aired helmet M05.

CB24-V4 Sand-blasting machine with work set, sand case. Abrasive tube d.16x30 mt.10 coupled, air kit. Aired helmet M05.

CB24-V5 Sand-blasting machine with work set, sand case. Abrasive tube d.16x30 mt.5 coupled, nozzle, sieve. Atoxic tube d. 8x17 mt.5 coupled, air kit. Aired helmet M06.

CB24-V6 Sand-blasting machine with work set, sand case. Abrasive tube d.16x30 mt.10 coupled, nozzle, sieve. Atoxic tube d.8x17 mt.10 coupled, air kit. Aired helmet M06.